



Please dispose of packaging for the product in a responsible manner. It is suitable for recycling. Help to protect the environment, take the packaging to the local amenity tip and place into the appropriate recycling bin.



Never dispose of electrical equipment or batteries in with your domestic waste. If your supplier offers a disposal facility please use it or alternatively use a recognised re-cycling agent. This will allow the recycling of raw materials and help protect the environment.

Sip
SIP INDUSTRIAL

machinery specialists since 1968

Professional Bench Grinder

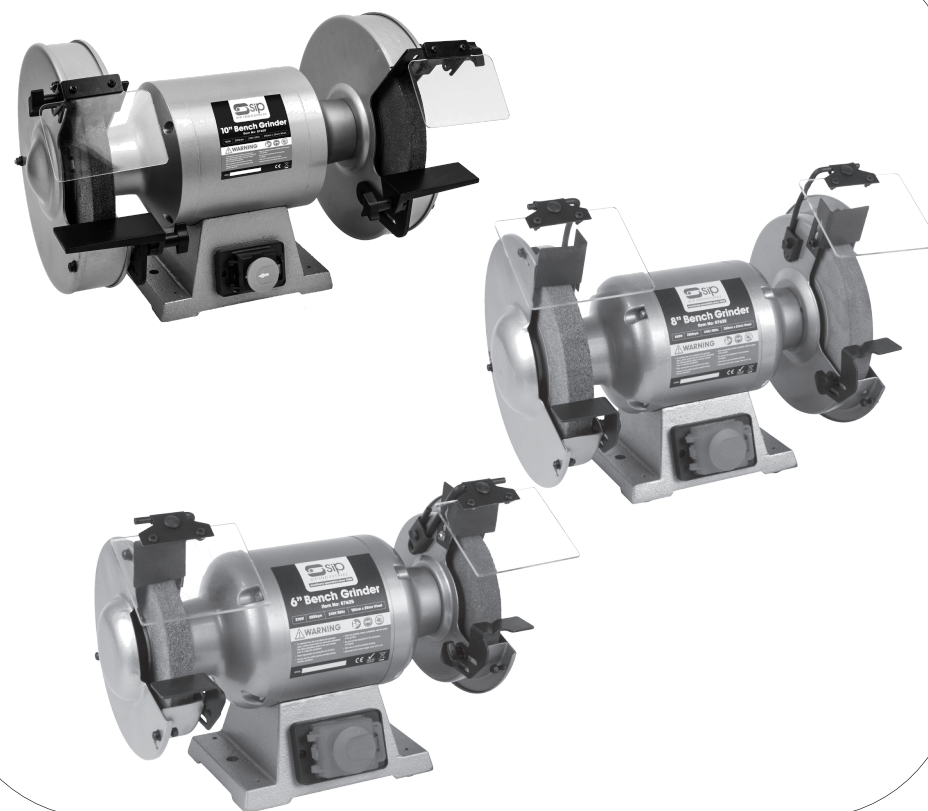

07625, 07628 & 07650

FOR HELP OR ADVICE ON THIS PRODUCT PLEASE CONTACT YOUR DISTRIBUTOR, OR SIP DIRECTLY ON:

TEL: 01509500400

EMAIL: sales@sip-group.com or technical@sip-group.com

www.sip-group.com

Ref: 16JUL2021

Please read and fully understand the instructions in this manual before operation. Keep this manual safe for future reference.

UK - DECLARATION OF CONFORMITY

UK - DECLARATION OF CONFORMITY

We

SIP (Industrial Products) Ltd
Gelders Hall Road
Shepshed
Loughborough
Leicestershire
LE12 9NH
England

As the manufacturer within the UK, England, Scotland & Wales,
declare that the

Conforms to the requirements of the following regulation /s, as indicated.

Supply of Machinery (Safety) Regulations 2008
Electromagnetic Compatibility Regulations 2016
Electrical Equipment (Safety) Regulations 2016
The Restriction of the Use of Certain Hazardous Substances in
Electrical and Electronic Equipment Regulations 2012

And the relevant harmonised standard(s), including,

BS EN 62841-1
BS EN 62841-3-4
BS EN 55014-1:2017
BS EN 55014-2:2015
BS EN IEC 61000-3-2:2019
BS EN 61000-3-3:2013+A1:2019

Signed: 

Mr P. Ippaso - Managing Director - SIP (Industrial Products) Ltd
Date: 16/07/2021.



EU - DECLARATION OF CONFORMITY

EU - Declaration of Conformity

We

ASM Chartered Accountants
First Floor, Block One,
Quayside Business Park
Dundalk
County Louth
Republic of Ireland

As the manufacturer's authorised representative within the
EC declare that the

6" Professional Bench Grinder - SIP Part No. 07625
8" Professional Bench Grinder - SIP Part No. 07628
10" Professional Bench Grinder - SIP Part No. 07650

Conforms to the requirements of the following directive(s), as indicated.

2006/42/EC	Machinery Directive
2014/35/EU	Low Voltage Directive
2014/30/EU	EMC Directive RoHS
2011/65/EU & 2015/863/EU	Directive

And the relevant harmonised standard(s), including,

EN 62841-1
EN 62841-3-4
EN 55014-1:2017
EN 55014-2:2015
EN IEC 61000-3-2:2019
EN 61000-3-3:2013+A1:2019

Signed: 

Mr P. Ippaso - Managing Director - SIP (Industrial Products) Ltd
Date: 16/07/2021.



For spare parts visit: www.sip-group.com/techzone
Alternatively call SIP After Sales 01 509 500400
Or
Email: technical@sip-group.com
Or
Web Chat: www.sip-group.com

<i>Page No.</i>	<i>Description</i>
4.	Safety Symbols Used Throughout This Manual
4.	Safety Instructions
8.	Technical Specifications
9.	Electrical Connection
10.	Guarantee
10.	Contents and Accessories
12.	Getting To Know Your Grinder
13.	Assembly Instructions
16.	Operating Instructions
17.	Maintenance
21.	Exploded Drawing - 07625
22.	Parts List - 07625
23.	Exploded Drawing - 07628
24.	Parts List - 07628
25.	Exploded Drawing - 07650
26.	Parts List - 07650
2 & 27.	UK & EU - Declaration of Conformity

SAFETY SYMBOLS USED THROUGHOUT THIS MANUAL



Danger / Caution: Indicates risk of personal injury and/or the possibility of damage.



Warning: Risk of electrical injury or damage!



Note: Supplementary information.

SAFETY INSTRUCTIONS



IMPORTANT: Please read the following instructions carefully, *failure to do so could lead to serious personal injury and / or damage to the bench grinder.*

When using electric tools / machines, basic safety precautions should always be followed to reduce the risk of fire, electric shock and personal injury. Read all these instructions before operating the grinder and save this user manual for future reference.

SIP recommends that this grinder should **not** be modified or used for any application other than that for which it was designed.

It was designed to be bench mounted, for driving abrasive wheels for the purpose of sharpening cutting tools such as chisels or drill bits. Alternatively it may be used to roughly shape metal prior to welding or fitting etc.

If you are unsure of its relative applications do not hesitate to contact us and we will be more than happy to advise you.

KNOW YOUR POWER TOOL: Read and understand the owner's manual and labels affixed to the grinder. Learn its applications and limitations, as well as the potential hazards specific to it.

KEEP WORK AREA CLEAN AND WELL LIT: Cluttered work benches and dark areas invite accidents. Floors must not be slippery due to oil, water or metal dust etc.

DO NOT USE THE TOOL IN DANGEROUS ENVIRONMENTS: Do not use power tools in damp or wet locations, or expose them to rain. Provide adequate space surrounding the work area. Do not use in environments with a potentially explosive atmosphere.

KEEP CHILDREN AND UNTRAINED PERSONNEL AWAY FROM THE WORK AREA: All visitors should be kept at a safe distance from the work area.

STORE TOOLS SAFELY WHEN THEY ARE NOT IN USE: All tools should be stored in a dry,

EXPLODED DRAWING 07650

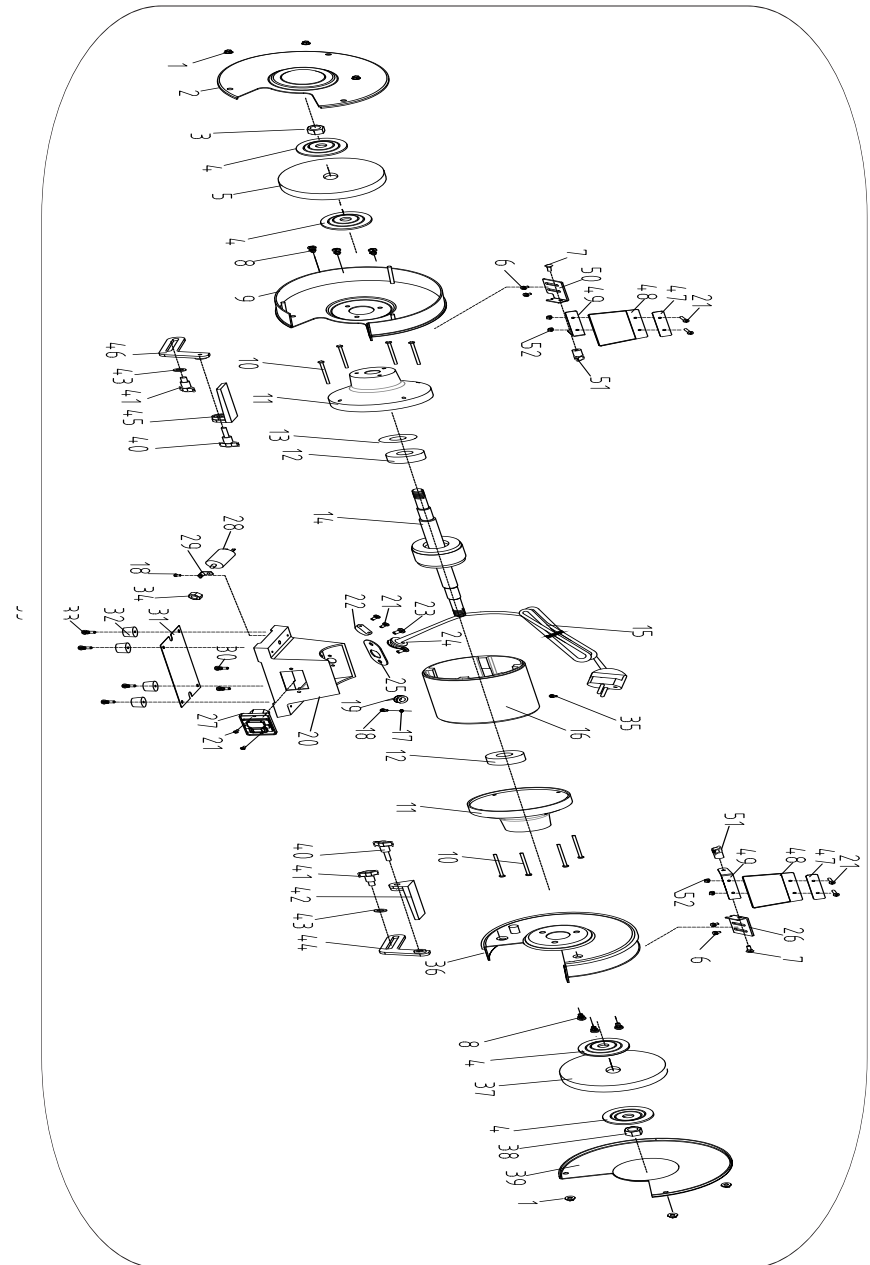

PARTS LIST 07628

Ref. No.	Description	Sip Part No.	Ref. No.	Description	Sip Part No.
1.	Screw M5x18	WK05-00095	27.	Mains lead	WK05-00118
2.	Left wheel cover	WK05-00141	28.	Right spark arrestor	WK05-00119
3.	Nut (16mm left)	WK05-00142	29.	Right eye shield arm	WK05-00120
4.	Outer flange	WK05-00143	30.	Eye shield	WK05-00151
5.	Coarse wheel 36 grit (200 x 25 x 15.8)	WK05-00144	31.	Right tool rest	WK05-00122
6.	Screw M5x10	WK05-00098	32.	Right cover plate	WK05-00152
7.	Left wheel guard	WK05-00145	33.	Fine wheel 60 grit (200 x 25 x 15.8)	WK05-00153
8.	Left spark arrestor	WK05-00100	34.	Nut (16mm right)	WK05-00154
9.	Washer 5mm	WK05-00101	35.	Right cover	WK05-00155
10.	Spring washer 5mm	WK05-00102	36.	Mains lead grommet	WK05-00125
11.	Screw M5x8	WK05-00103	37.	Lock washer	WK05-00126
12.	Bolt M5x20	WK05-00104	38.	Screw M4x8	WK05-00127
13.	Nut 5mm	WK05-00105	39.	Base	WK05-00128
14.	Left tool rest	WK05-00106	40.	Strain relief bush	WK05-00129
15.	Washer 5mm (big)	WK05-00107	41.	Capacitor 10mf	WK05-00188
16.	Lock knob	WK05-00187	42.	Capacitor support	WK05-00131
17.	End cap	WK05-00146	43.	Nut 8mm	WK05-00132
18.	Bolt M6x14	WK05-00109	44.	Screw M4x8	WK05-00133
19.	Washer 6mm	WK05-00110	45.	Rubber foot	WK05-00134
20.	Bracket	WK05-00111	46.	Bottom cover	WK05-00135
21.	Left eye shield arm	WK05-00112	47.	Bolt M8x22	WK05-00136
22.	Eye shield holder	WK05-00113	48.	Screw M5x16	WK05-00137
23.	Spring washer	WK05-00147	49.	NVR switch KJD18	WK05-00138
24.	Bearing	WK05-00148	50.	Inner flange	WK05-00156
25.	Stator	WK05-00149	51.	Wire wheel	WK05-00157
26.	Rotor	WK05-00150	52.	Washer for wire wheel	WK05-00158

SAFETY INSTRUCTIONS...cont

locked cupboard wherever possible and out of the reach of children.

WEAR THE CORRECT CLOTHING: Do not wear loose clothing, neckties, rings, bracelets, or other jewellery, which may get caught in moving parts. Non-slip footwear is recommended. Wear protective hair covering to contain long hair. Roll long sleeves up above the elbow.

USE SAFETY GOGGLES AND EAR PROTECTION ETC: Wear CE approved safety goggles at all times, normal spectacles only have impact resistant lenses, they are **NOT** safety glasses. A face or dust mask should be worn if the operation is dusty and ear protectors (plugs or muffs) should be worn, particularly during extended periods of operation.

PROTECT YOURSELF FROM ELECTRIC SHOCK: When working with power tools, avoid contact with any earthed items (e.g. pipes, radiators, hobs and refrigerators, etc.). It is advisable wherever possible to use an RCD (residual current device) at the mains socket or supply board.

STAY ALERT: Always watch what you are doing and use common sense. Do not operate a grinder when you are tired or under the influence of alcohol or drugs.

DISCONNECT THE TOOL FROM THE MAINS SUPPLY: When not in use, before servicing and when changing accessories such as wheels.

AVOID UNINTENTIONAL STARTING: Make sure the switch is in the **OFF** position before connecting the grinder to the mains supply.

NEVER LEAVE THE TOOL RUNNING / CONNECTED WHILST UNATTENDED: Turn off the tool and disconnect it from the mains supply between jobs. Do not leave the machine until it comes to a complete stop.

DO NOT ABUSE THE MAINS LEAD: Never carry or move the grinder by the mains lead or pull it to remove the plug from the mains socket. Keep the mains lead away from heat, oil and sharp edges. If the mains lead is damaged, it must be replaced by the manufacturer or its service agent or a similarly qualified person in order to avoid unwanted hazards.

CHECK FOR DAMAGED PARTS: Before every use of the grinder, a guard or other part that is damaged should be carefully checked to determine that it will operate correctly and perform its intended function. Check for alignment of moving parts, free running of moving parts, breakage of parts, and any other conditions that may affect its operation. A guard or other part that is damaged should be correctly repaired or replaced by an authorised service centre unless otherwise indicated in this instruction manual. Have defective switches replaced by an authorised service agent. Do not use the tool if the switch does not turn it on and off.

KEEP ALL GUARDS IN PLACE: And in full working order.

MAINTAIN TOOLS WITH CARE: Keep tools sharp and clean for the best and safest performance. Follow instructions for lubricating and changing accessories. All extension cables must be checked at regular intervals and replaced if damaged.

USE ONLY RECOMMENDED ACCESSORIES: Consult this user manual for recommended accessories. Follow the instructions that accompany the accessories. The use of improper accessories may cause hazards and will invalidate any warranty you may

SAFETY INSTRUCTIONS...cont

have.

REMOVE ADJUSTING KEYS AND WRENCHES: Form a habit of checking to see that keys and adjusting wrenches are removed from the tool before every use.

DO NOT OVERREACH: Keep proper footing and balance at all times.

USE THE RIGHT TOOL: Do not use the tool or attachment to do a job for which it was not designed.

DO NOT FORCE THE TOOL: It will do the job better and more safely at the rate which it was designed.

DO NOT OPERATE POWER TOOLS IN EXPLOSIVE ATMOSPHERES: Do not use the grinder in the presence of flammable liquids, gases, dust or other combustible sources. Grinding will create sparks which can ignite the dust or fumes.

DO NOT EXPOSE THE TOOL TO RAIN OR USE IT IN WET CONDITIONS: Water entering the grinder will greatly increase the risk of electric shock.

KEEP THE MAINS LEAD WELL AWAY FROM THE CUTTING WHEEL: The mains lead should be secured away from the cutting wheel at all times to avoid the risk of electric shocks. Replace any damaged or tired looking leads immediately with the correct rated cable.

ALWAYS CHECK THE WHEEL: Always inspect the wheel for cracks and general condition before use as they could shatter at high speed causing injury to the operator and fellow work mates . If using an old wheel ensure that it hasn't gone soft as the bond that holds it together can go off over time.

- Use only the wheel flanges and nuts specified for this tool.
- Before each use; Ensure that the wheel retaining nuts are fully secure.
- Ensure that the grinder is securely bolted to a stable surface so it will not move during operation.
- Ensure that all keys and wrenches are removed before operating the grinder.
- Ensure that the work-piece to be ground is clear of the grinding wheel before the switch is turned on.
- Before turning on the grinder, turn the wheel by hand to ensure nothing is catching, then turn the grinder on and let it run for a while; Watch for vibration or excessive wobble of the wheel that could indicate poor installation or a poorly balanced wheel. Adjust or replace as necessary.
- Allow the wheel to run up to full speed before grinding.
- Stop operation immediately if you notice, or suspect anything abnormal.
- Wait for the grinder to stop completely and remove the plug from the mains supply before servicing or adjusting the grinder.
- Be alert at all times, especially during repetitive, monotonous operations. Don't be lulled into a false sense of security. Grinding wheels are extremely unforgiving.
- Do not modify the grinder to do tasks other than those for which it was designed.
- Ensure tool rests and eye shields are correctly adjusted.

EXPLODED DRAWING 07628

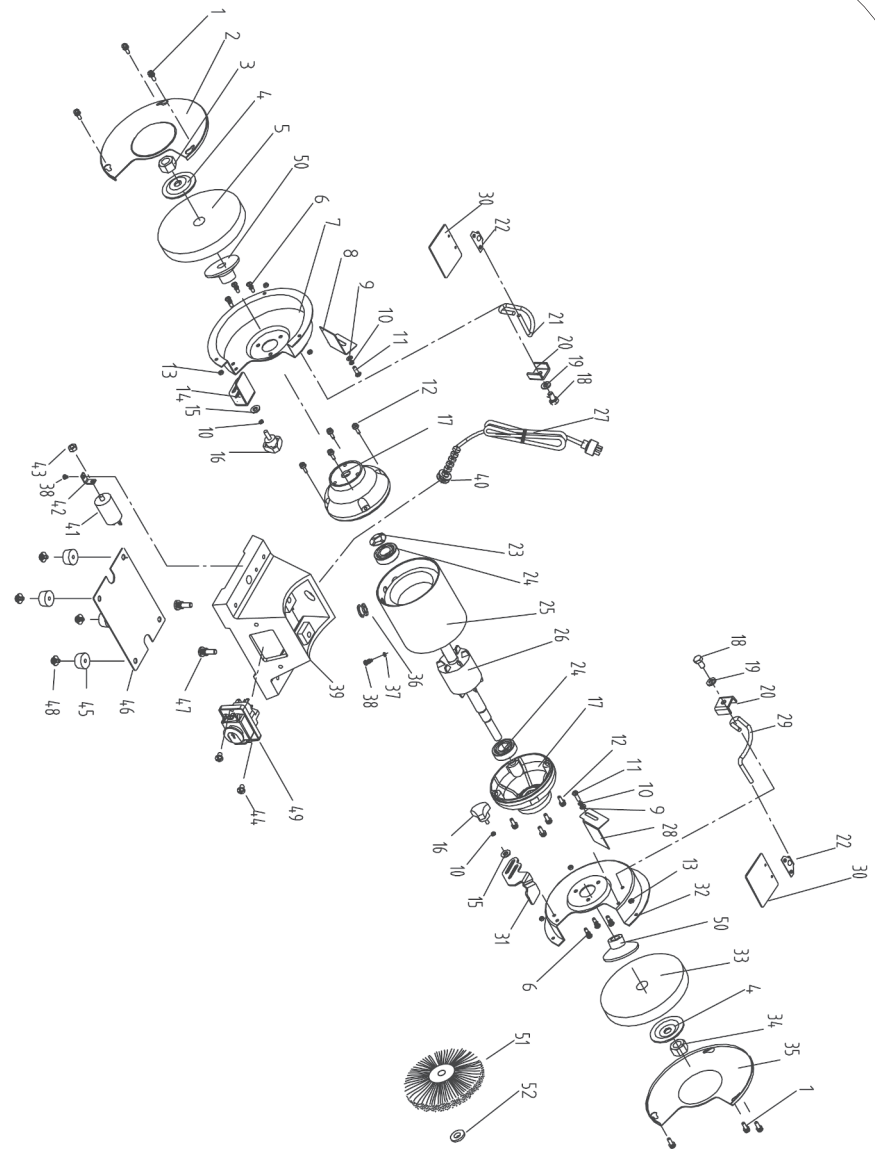

PARTS LIST 07625

Ref. No.	Description	Sip Part No.	Ref. No.	Description	Sip Part No.
1.	Screw M5x18	WK05-00095	27.	Mains lead	WK05-00118
2.	Left wheel cover	WK05-00096	28.	Right spark arrestor	WK05-00119
3.	Nut (12mm left)	WK05-00004	29.	Right eye shield arm	WK05-00120
4.	Flange	WK05-00097	30.	Eye shield	WK05-00121
5.	Coarse wheel 36 grit (150 x 20 x 12.7)	17638	31.	Right tool rest	WK05-00122
6.	Screw M5x10	WK05-00098	32.	Right cover plate	WK05-00123
7.	Left wheel guard	WK05-00099	33.	Fine wheel 60 grit (150 x 20 x 12.7)	17632
8.	Left spark arrestor	WK05-00100	34.	Nut (12mm right)	WK05-00006
9.	Washer 5mm	WK05-00101	35.	Right cover	WK05-00124
10.	Spring washer 5mm	WK05-00102	36.	Mains lead grommet	WK05-00125
11.	Screw M5x8	WK05-00103	37.	Lock washer	WK05-00126
12.	Bolt M5x20	WK05-00104	38.	Screw M4x8	WK05-00127
13.	Nut 5mm	WK05-00105	39.	Base	WK05-00128
14.	Left tool rest	WK05-00106	40.	Strain relief bush	WK05-00129
15.	Washer 5mm (big)	WK05-00107	41.	Capacitor 8mf	WK05-00130
16.	Lock knob	WK05-00187	42.	Capacitor support	WK05-00131
17.	End cap	WK05-00108	43.	Nut 8mm	WK05-00132
18.	Bolt M6x14	WK05-00109	44.	Screw M4x8	WK05-00133
19.	Washer 6mm	WK05-00110	45.	Rubber foot	WK05-00134
20.	Bracket	WK05-00111	46.	Bottom cover	WK05-00135
21.	Left eye shield arm	WK05-00112	47.	Bolt M8x22	WK05-00136
22.	Eye shield holder	WK05-00113	48.	Screw M5x16	WK05-00137
23.	Spring washer	WK05-00114	49.	NVR switch KJD18	WK05-00138
24.	Bearing	WK05-00115	50.	Wire wheel	WK05-00139
25.	Stator	WK05-00116	51.	Washer for wire wheel	WK05-00140
26.	Rotor	WK05-00117			

SAFETY INSTRUCTIONS...cont

- Only use grinding wheels that are rated for the correct speed.
- Do not overload the grinding wheel; stalling the machine will shorten its life.
- After fitting new grinding wheel, leave machine running for at least one minute. If the wheel is faulty it will break during this test period.
- Stand to the side of the grinder during initial start up.
- Use a wheel dresser only to remove burrs on the grinding wheel.
- If the grinder is used in a place of work all rules and laws etc. relating to the use of portable electrical appliances should be followed.



When using the grinder always ensure the operator as well as those in the area wear eye protection.



Grinding produces particles which can become airborne and have the potential to be highly toxic; always wear a face mask when operating the grinder.



When using the grinder always ensure the operator as well as those in the area wear ear protection, particularly during periods of extended use.



Caution: The warnings and cautions mentioned in this user manual can not cover all possible conditions and situations that may occur. It must be understood by the operator that common sense and caution are factors which cannot be built into this product, but must be applied.

TECHNICAL SPECIFICATIONS

Part No.	07625	07628	07650
Description	6" Bench Grinder	8" Bench Grinder	10" Bench Grinder
Input Voltage	230v 50Hz	230v 50Hz	230v 50Hz
Motor	370w S2 30Mins	550w S2 30Mins	750w S2 30Mins
Wheel Speed	2980rpm	2980rpm	2980rpm
Duty Cycle	250w S1	370w S1	550w S1
Wheel Dimensions (mm)	Ø150 x 20 x Ø12.7mm	Ø200 x 25 x Ø15.88mm	Ø250 x 25 x Ø20mm
Protection	IP23	IP23	IP23
Net Weight	6.29Kg	9.26Kg	24Kg

EXPLODED DRAWING 07625

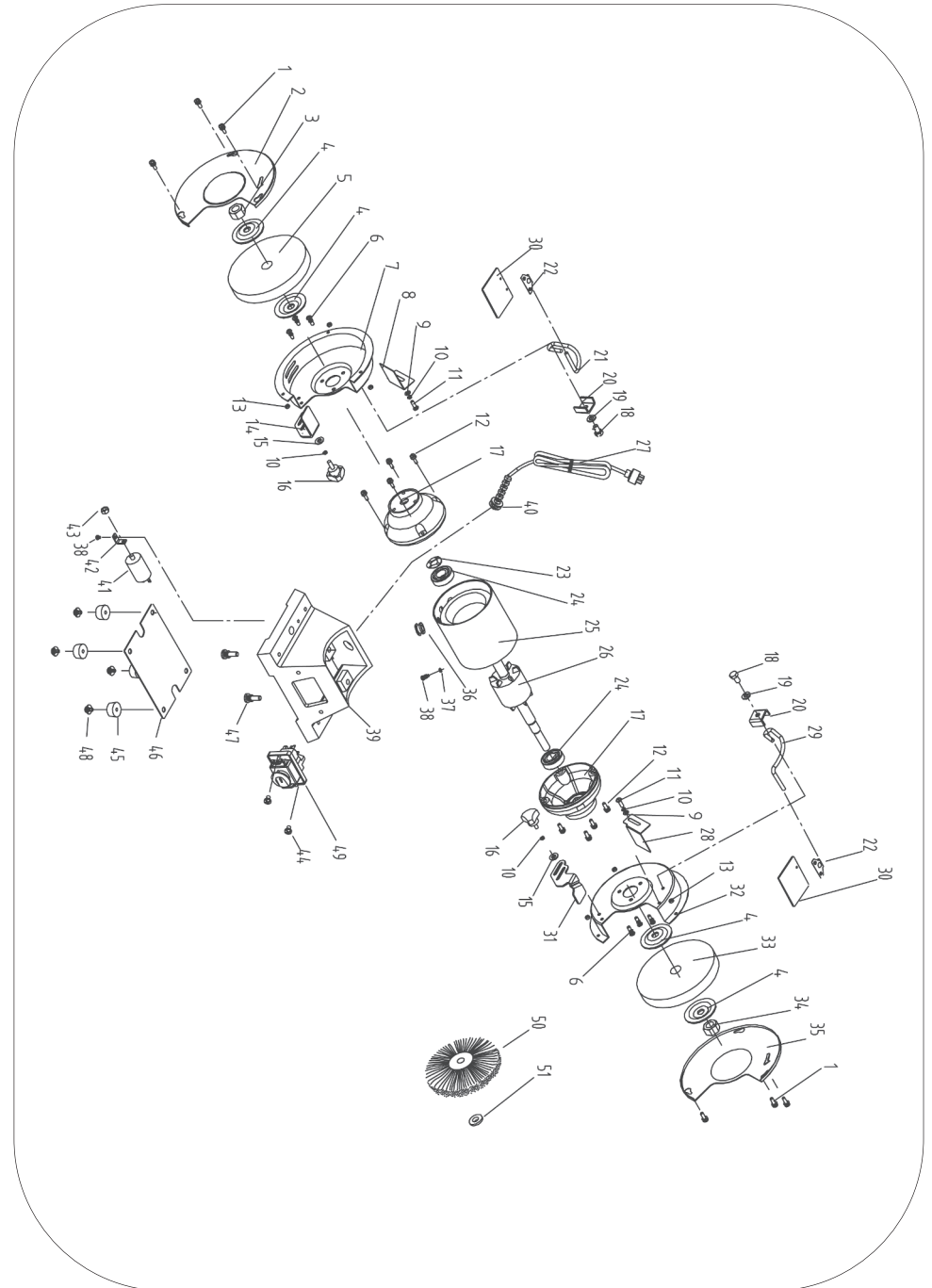

MAINTENANCE...cont

- Hold the grinding wheel, or the opposite one, with one hand and turn the retaining nut clockwise for the left hand wheel, and anti clockwise for the right hand wheel.



Note: Wear a protective glove to hold the grinding wheel whilst loosening the retaining nut.

- Remove the nut, outer flange and the grinding wheel.
- Ensure that the shaft and flanges are clean and free from burrs etc.
- Refit the flanges and wheel etc. as shown below.
- Follow the instructions above, but in reverse to secure the new wheel and cover etc.

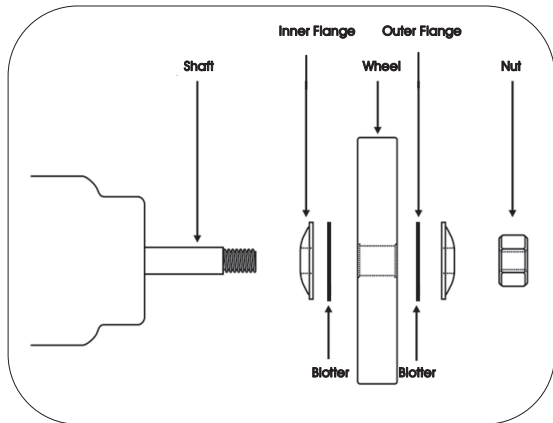

Note: Do not over tighten the retaining nut; it needs to be tight enough to hold the grinding wheel, but not so tight so that it damages the flanges.

ELECTRICAL CONNECTION

These grinders are fitted with a standard UK type 230v ~ plug. Before using the grinder inspect the cable and plug to ensure that neither are damaged. If any damage is visible have the grinder inspected / repaired by a suitably qualified person. If it is necessary to replace the plug a heavy duty impact resistant plug would be preferable.

The wires for the plug are coloured in the following way:

Yellow / green	Earth
Blue	Neutral
Brown	Live

As the colours of the wires may not correspond with the markings in your plug, proceed as follows: The wire which is coloured blue, must be connected to the terminal marked with N or coloured black. The wire which is coloured brown, must be connected to the terminal, which is marked L or coloured red. The wire which is coloured yellow / green should be connected to the terminal which is coloured the same or marked.

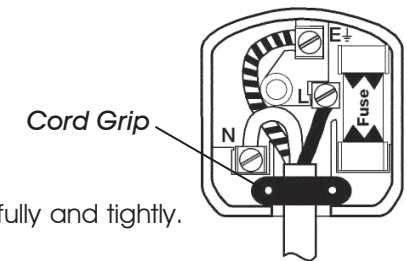

Always secure the wires in the plug terminal carefully and tightly. Secure the cable in the cord grip carefully.



Warning: Never connect live or neutral wires to the earth terminal of the plug. Only fit an approved plug with the correct rated fuse. If in doubt consult a qualified electrician.



Note: Always make sure the mains supply is of the correct voltage and the correct fuse protection is used. In the event of replacing the fuse always replace the fuse with the same value as the original.



Note: If an extension lead is required in order to reach the mains supply; ensure that this too is rated for the correct voltage and fuse rating.



Note: The cross section of the extension lead should be checked so that it is of sufficient size so as to reduce the chances of voltage drops.

GUARANTEE

These SIP Bench Grinders are covered by a 12 month parts and labour warranty covering failure due to manufacturers defects. This does not cover failure due to misuse or operating the grinders outside the scope of this manual - any claims deemed to be outside the scope of the warranty may be subject to charges including, but not limited to parts, labour and carriage costs. Consumable items such as grinding wheels are not covered by the warranty.

In the unlikely event of warranty claims, contact your distributor as soon as possible.



Note: Proof of purchase will be required before any warranty can be honoured.

CONTENTS AND ACCESSORIES

07625 & 07628

1. Bench Grinder c/w 2 x Grinding Wheels (not pictured).
2. Spark Arrestor x 2 (inc. fixings).
3. Eye Shield Assembly x 2 (1 x Left & 1 x Right).
4. Tool Rest Assembly x 2 (inc. fixings).
5. Instruction Manual (not pictured).

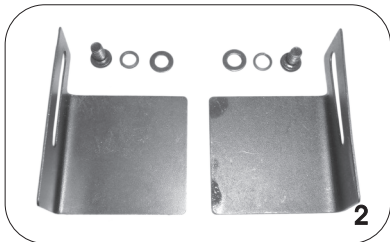

2



4

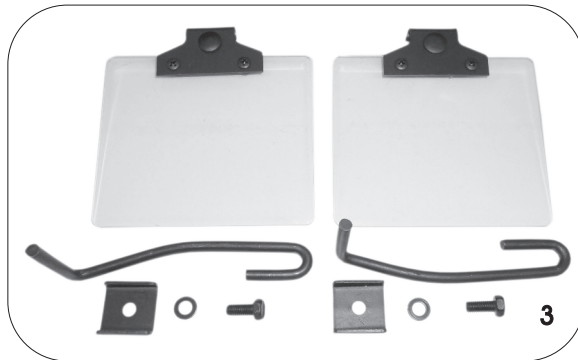

3

MAINTENANCE...cont

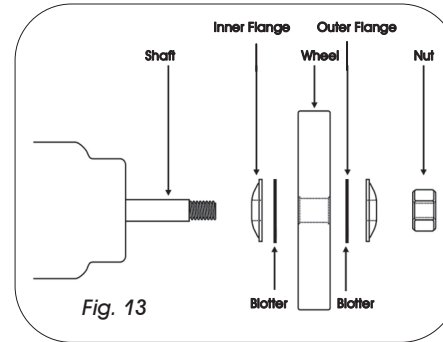

Fig. 13



Note: Do not over tighten the retaining nut; it needs to be tight enough to hold the grinding wheel, but not so tight so that it damages the flanges.

REPLACING THE GRINDING WHEELS 07650



Warning! Always ensure that a 'blotter' (cardboard disc between the flange and the grinding wheel) is fitted either side of the grinding wheel.



Warning! Always ensure that the replacement wheel is of the correct size and rated for the speed of the grinder as stated in the specifications.

- Loosen and remove the 3 guard retaining nuts (Fig. 14).
- Remove the side guard.

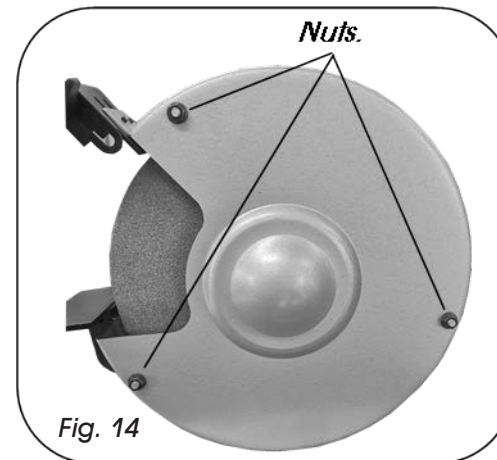

Fig. 14

MAINTENANCE...cont

REPLACING THE GRINDING WHEELS 07625 & 28



Warning! Always ensure that a 'blotter' (cardboard disc between the flange and the grinding wheel) is fitted either side of the grinding wheel.



Warning! Always ensure that the replacement wheel is of the correct size and rated for the speed of the grinder as stated in the specifications.

Over time during normal usage the grinding wheels will become worn and need to be replaced.

- Loosen the 3 screws that hold the side cover on (Fig. 11).
- Rotate the cover clockwise slightly so that the screw heads line up with the holes on the side cover (Fig. 12); Remove the cover.

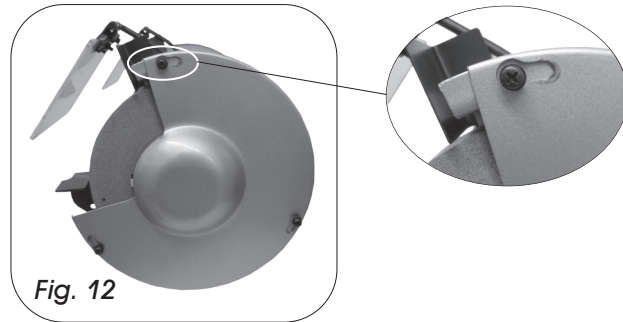
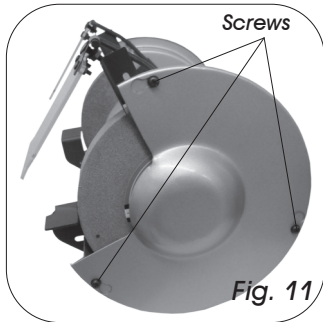

- Hold the grinding wheel, or the opposite one, with one hand and turn the retaining nut clockwise for the left hand wheel, and anti clockwise for the right hand wheel.



Note: Wear a protective glove to hold the grinding wheel whilst loosening the retaining nut.

- Remove the nut, outer flange and the grinding wheel.
- Ensure that the shaft and flanges are clean and free from burrs etc.
- Refit the flanges and wheel etc. as shown on page 19, Fig. 13.
- Follow the instructions above, but in reverse to secure the new wheel and cover etc.

CONTENTS AND ACCESSORIES...cont

07650

1. Bench Grinder c/w 2 x Grinding Wheels (not pictured).
2. Spark Arrestor x 2.
3. Eye Shield Assembly x 2 (1 x Left & 1 x Right) see Below
4. Tool Rest Assembly x 2 (inc. fixings) see below.
5. Instruction Manual (not pictured).

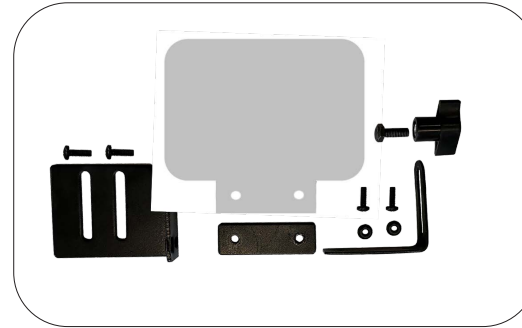

Note: If any parts are missing, or damaged, contact your distributor immediately for the missing parts to be replaced.

GETTING TO KNOW YOUR BENCH GRINDER

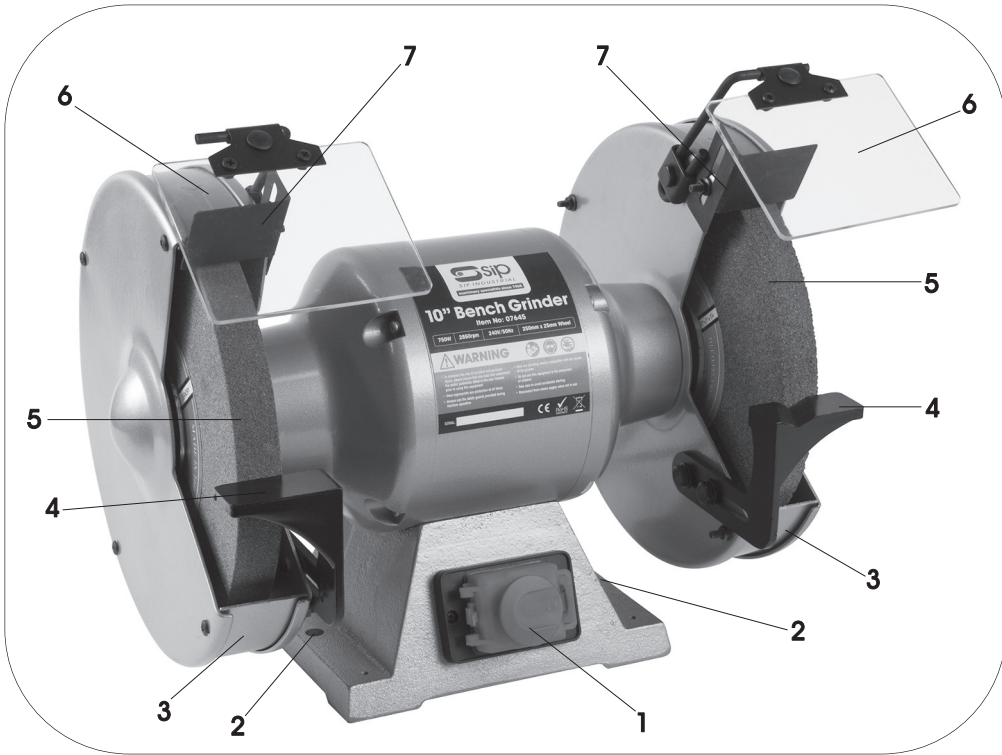

Ref. No.	Description	Ref. No.	Description
1.	On/Off Switch **	5.	Grinding Wheel
2.	Mounting Hole	6.	Eye Shield
3.	Guard	7.	Spark Arrestor
4.	Tool Rest		

OPERATING INSTRUCTIONS...cont



Warning! Always ensure that the grinder is bolted down onto a secure surface prior to operation.

SWITCHING THE GRINDER ON/OFF

The grinder is fitted with an NVR (No Volt Release) switch; This means that if power is cut to the grinder it will not restart once the power is restored to the grinder.

The switch is located on the front of the grinder near the bottom.

To turn the grinder on, lift the cover and depress the green (I) switch.

To turn the grinder off, depress the red (O) button or close the cover.



Note: Before starting the grinder, turn the wheels by hand making sure they are clear of obstructions and that they turn freely. The tool rests and eye shields should not touch the wheel.



Note: Turn on the grinder and allow it to reach full running speed before starting to grind.

MAINTENANCE



Warning! Always ensure that the grinder is turned off and that the plug is disconnected from the mains supply before carrying out any adjustments, repairs or maintenance.

CLEANING AND ADJUSTMENTS

As the wheels wear, adjust the positions of the tool rests and spark arrestors; They should be set so that they are as close to the grinding wheel as possible, but without touching.

Regularly remove the wheel covers and clean out any dust and dirt.

The machine motor and bearings are sealed units and require no regular maintenance.

The eye shields should be cleaned regularly so that the operator has a clear view of the work-piece and grinding wheel. Mild soap and water should be used; never use solvents or similar products as they will damage the eye shield/s.

ASSEMBLY INSTRUCTIONS...cont

FITTING THE TOOL REST 07650 CONT.



Note: As with spark arrestor, the tool-rest should be set close to the grinding wheel, without touching; turn the wheel by hand to ensure there is no contact.

OPERATING INSTRUCTIONS



Note: Before each operation; Turn the grinding wheel by hand to ensure that the wheel turns freely without catching the tool rest etc.



Danger: Always ensure that the wheel retaining nut is fully tightened and the wheel is secure before each operation.

Wheel Balancing:

If the wheels are not running true and eccentric they may need to be balanced.

This can be easily achieved by removing the wheel guards and unscrewing the wheel retaining nut slightly. Then hold the other grinding wheel at the same time as slightly rotating the out of balance wheel. Re-tighten and spin the wheel by hand. Repeat until the wheel is running true / concentric. Refit the wheel guard.

MAKE SURE THE GRINDER IS SWITCHED OFF AND UNPLUGGED WHEN PERFORMING THIS TASK.

Correct working practice:

Maintain a steady, moderate pressure on the work piece and keep it moving at an even pace for smooth grinding.

Pressing too hard overheats the motor and prematurely wears down the grinding wheels. The grinding wheel should rotate into the object, being sharpened. Keep a tray filled with water and dip your work into it regularly to prevent overheating.

Do not use the side of the grinding wheel; This puts dangerous stress on the wheel.

When the wheel becomes loaded or 'dull', use an approved grinding wheel dresser and dress the wheel face.

ASSEMBLY INSTRUCTIONS

FITTING THE SPARK ARRESTOR 07625 & 28

There are 2 holes on the inside of the guards (Fig. 1); A smaller one towards the front to attach the spark arrestor, and a larger one towards the back to attach the eye shield.

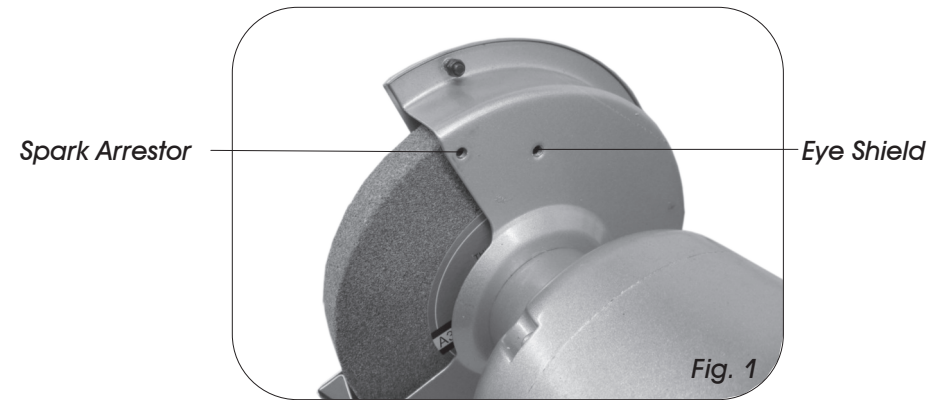

Fit the spark arrestor and secure in place with the screw, spring washer and washer (Fig. 2).

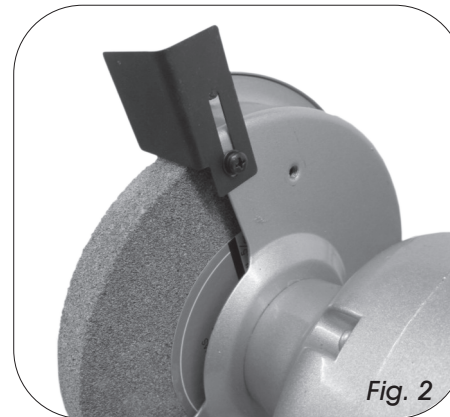

Note: The spark arrestor should be set close to the grinding wheel, without touching it; turn the wheel by hand to ensure there is no contact.

Follow these instructions to fit the 2nd spark arrestor to the opposite side of the grinder (07625 & 07628 only).

ASSEMBLY INSTRUCTIONS...cont

FITTING THE SPARK ARRESTOR 07650

Fit the spark arrestor with the 2 screws provided as shown in Fig.3



Note: The spark arrestor should be set close to the grinding wheel, without touching; turn the wheel by hand to ensure there is no contact.



Fig. 3

FITTING THE EYE-SHIELD

Fit the clear eye-shield to the "L" shaped bracket and secure in place together with the screws and retaining plate.

Fasten the assembled eye shield to the spark arrestor bracket using the bolt and "T" shaped hand nut. Connect via the slotted "L" shaped bracket, which can be adjusted up & down. (Fig.4)
Repeat for both sides.

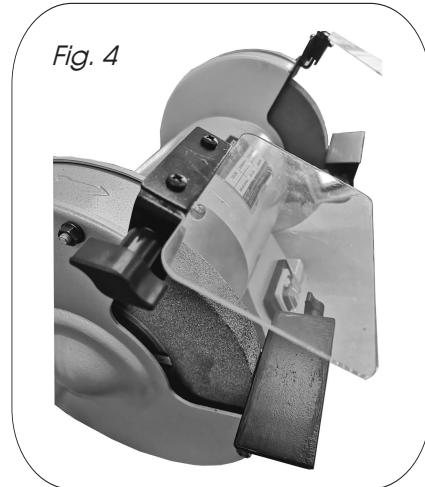

Fig. 4



Note: Take care not to over tighten the bolt as this will damage the guard; It only needs to be tight enough to hold the eye shield in place whilst allowing the operator to easily change the angle.

ASSEMBLY INSTRUCTIONS...cont

FITTING THE TOOL REST 07625 & 28

The tool rest fits to the inside of the guard towards the bottom (Fig. 5). Use the supplied thumbscrew, spring washer and washer to secure in place (Fig. 6).

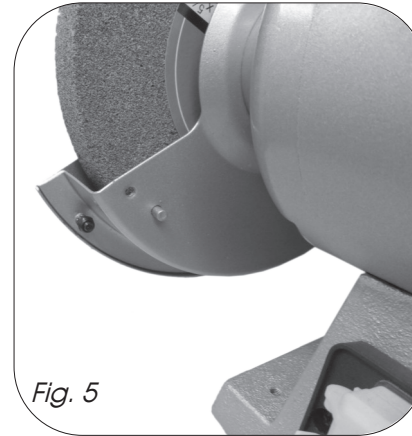

Fig. 5

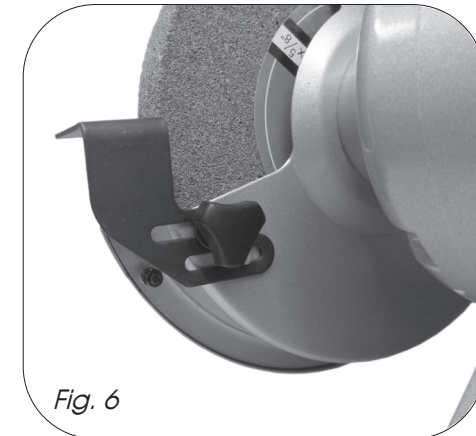

Fig. 6

Follow these instructions to fit the 2nd tool-rest to the opposite side (07625 & 07628 only).

FITTING THE TOOL REST 07645

Fit the "L" shaped part of the tool rest to the inside of the guard. Use the thumbscrew provided (M8).

Fit the adjustable platen part of the tool rest as shown in Fig. 7. Use the thumbscrew provided (M6)



Fig. 7